

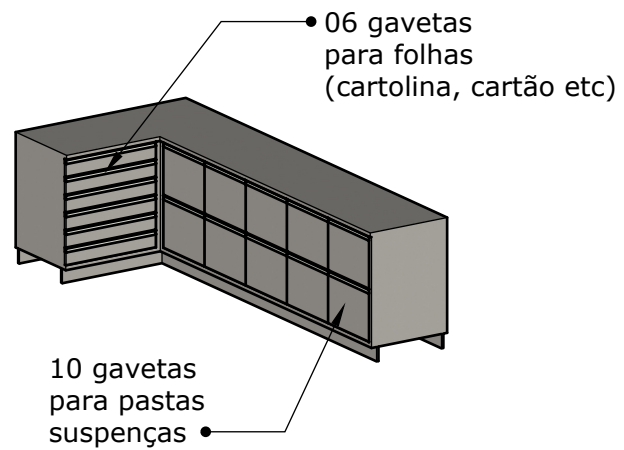

PROJETO EXECUTIVO

CLIENTE: PREFEITURA MUNICIPAL DE CAPINZAL
EXECUÇÃO: CRECHE VERDES CAMPOS

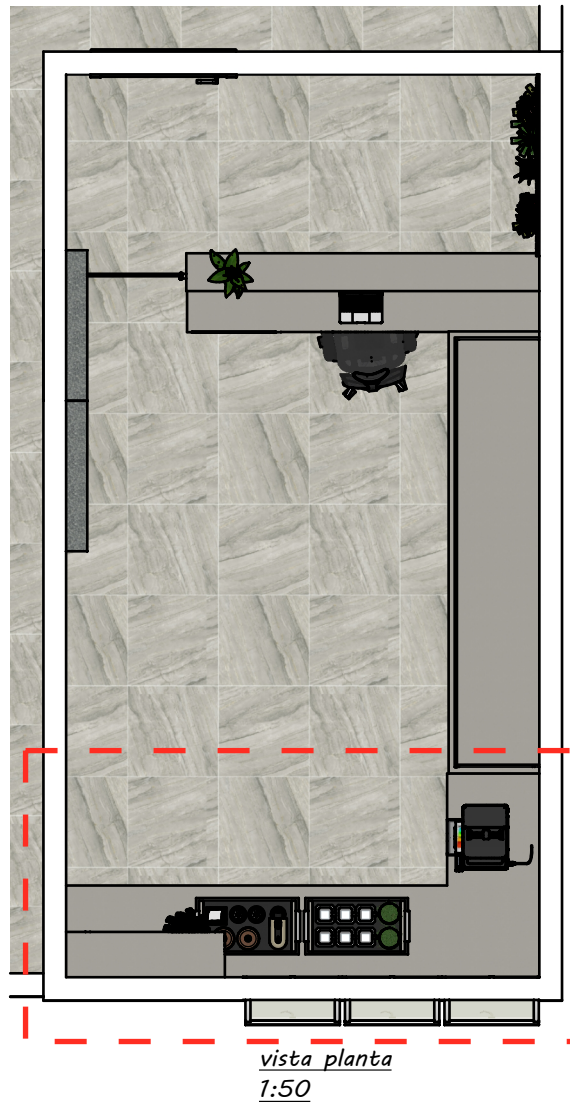

vista perspectiva
1:50

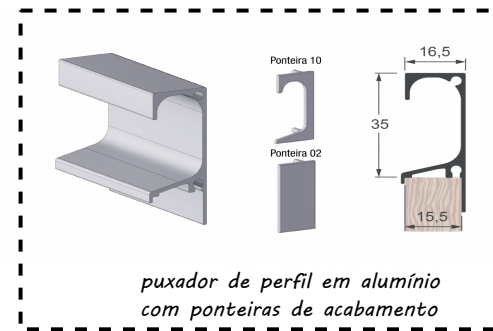
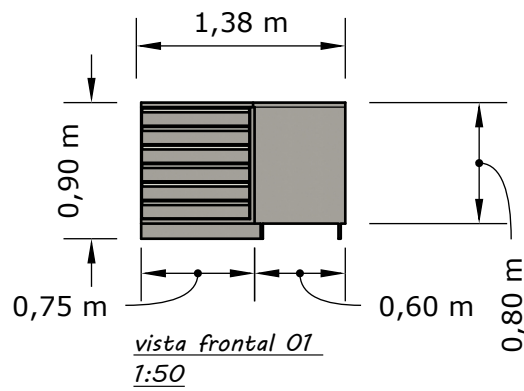

detalhes gerais

- *puxadores em perfil Bilbao com ponteiros de acabamento
- *móvel confeccionado em mdf cinza de 15mm
- *corrediças telescópicas reforçada (larga)
- *dobradiças com sistema de amortecimento (fechamento suave)
- *trilhos superiores e inferiores em alumínio
- *sistema de rodízios de portas rolamentado

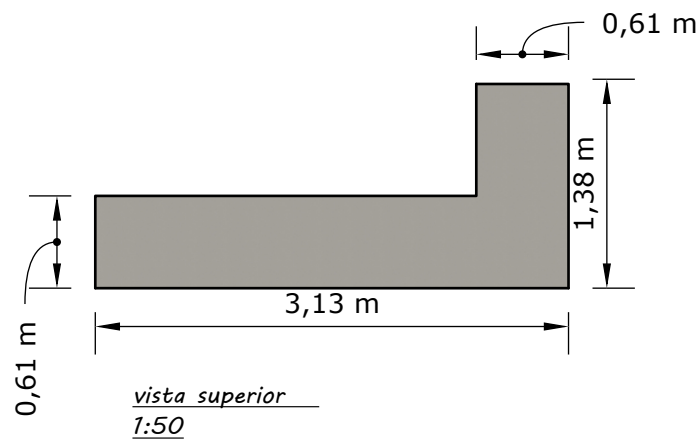
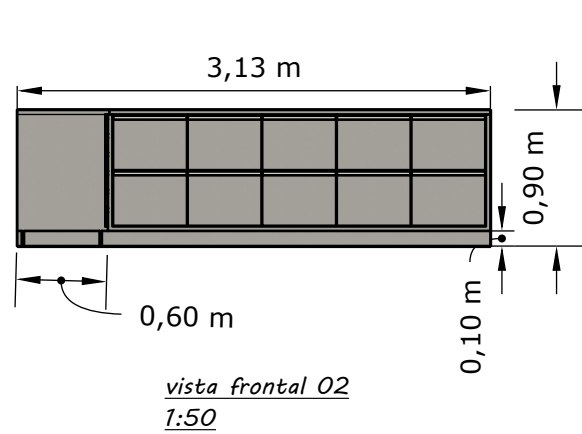

Studio link
projetos de interiores
(49) 99828-6943

Cliente: pref capinzal
Local: capinzal

Projeto: secretaria
Data: 03/01/2024

Responsável técnico;
Jackson Schuster

Escala: 1/50

A 01

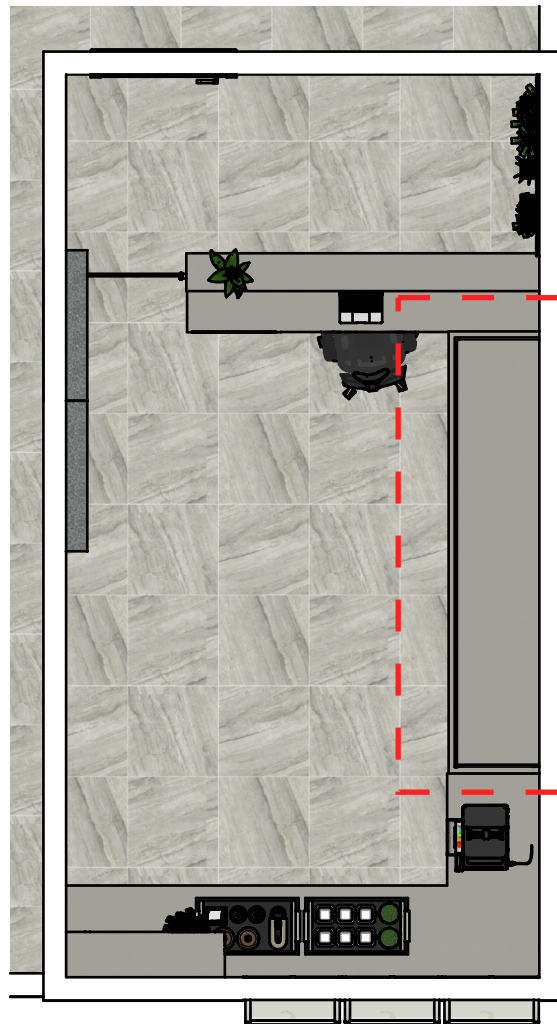

vista planta
1:50

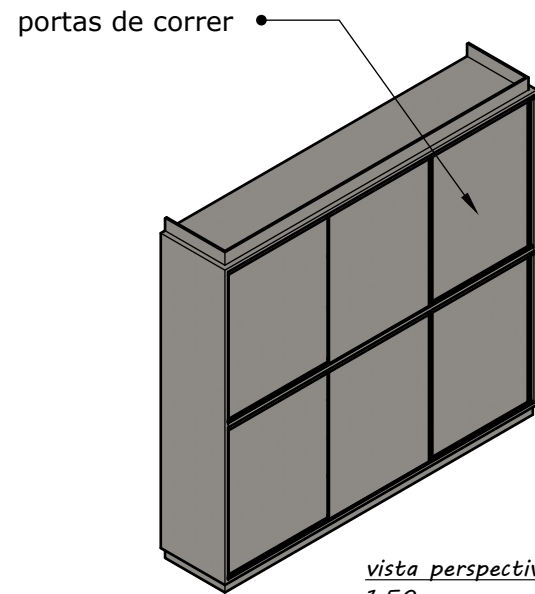

vista perspectiva
1:50

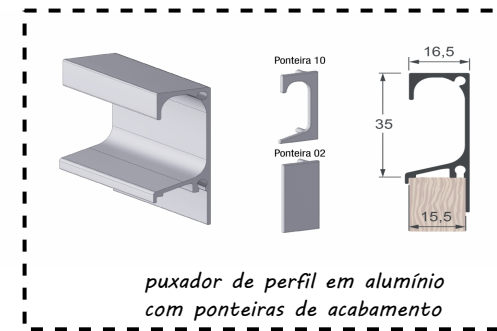

puxador de perfil em alumínio
com ponteiros de acabamento

detalhes gerais

- *puxadores em perfil Bilbao com ponteiros de acabamento
- *móvel confeccionado em mdf cinza de 15mm
- *corrediças telescópicas reforçada (larga)
- *dobradiças com sistema de amortecimento (fechamento suave)
- *trilhos superiores e inferiores em alumínio
- *sistema de rodízios de portas rolamentado

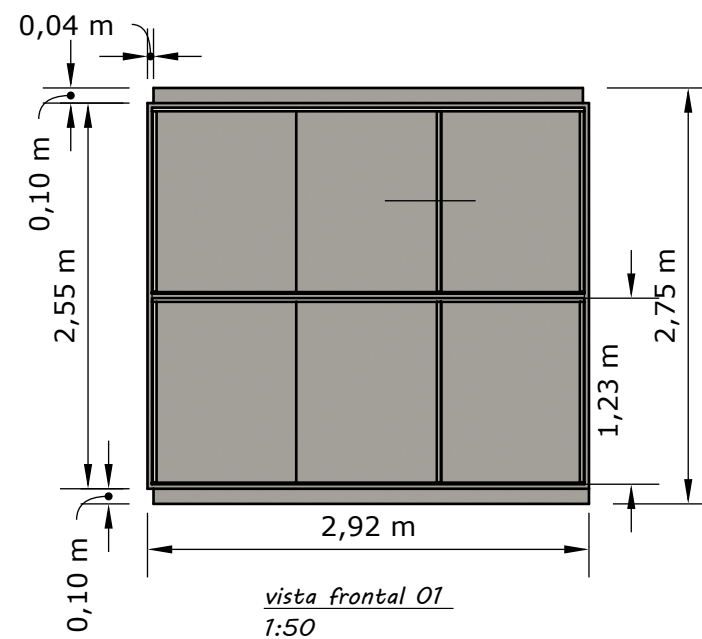

vista frontal 01
1:50

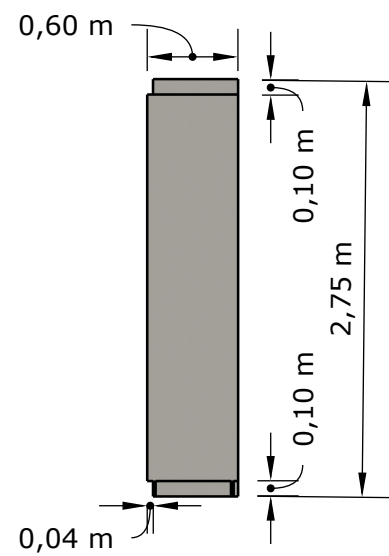

vista lateral
1:50

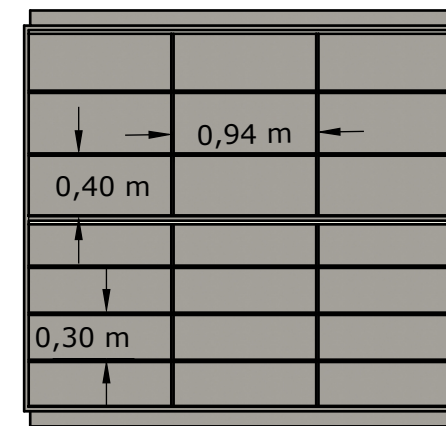

vista frontal (interno)
1:50



Studio link
projetos de interiores
(49) 99828-6943

Cliente: pref capinzal
Local: capinzal

Projeto: secretaria
Data: 03/01/2024

Responsável técnico;
Jackson Schuster

Escala: 1/50

A 02

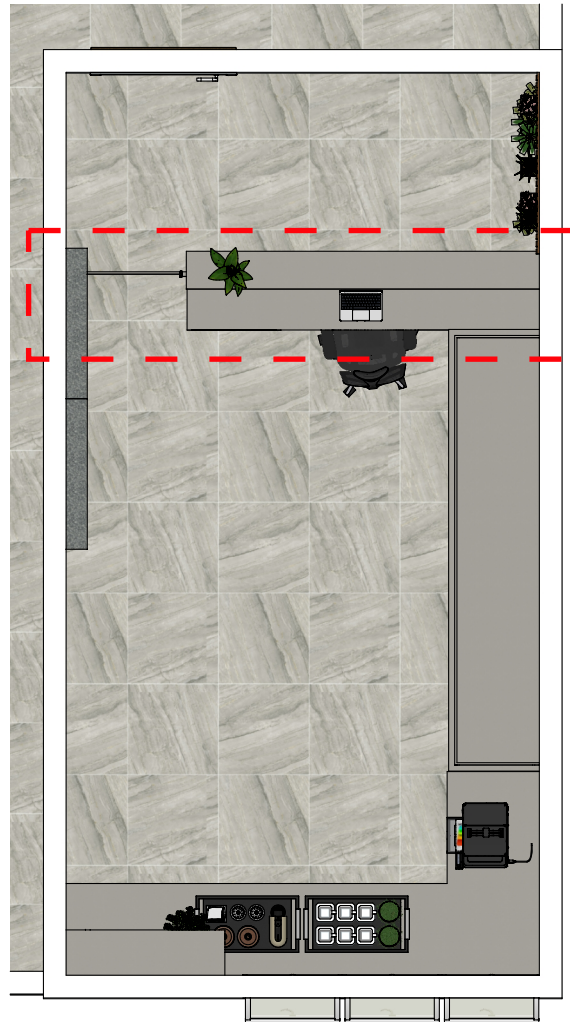

vista planta
1:50

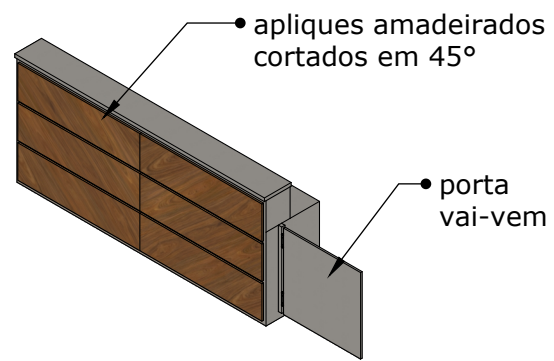

vista perspectiva
1:50

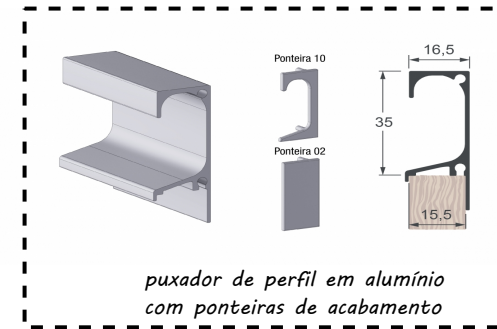

detalhes gerais

- *puxadores em perfil Bilbao com ponteiros de acabamento
- *móvel confeccionado em mdf cinza de 15mm
- *detalhes das frentes em mdf amadeirado
- *corrediças telescópicas reforçada (larga)
- *dobradiças com sistema de amortecimento (fechamento suave)
- *trilhos superiores e inferiores em alumínio
- *sistema de rodízios de portas rolamentado

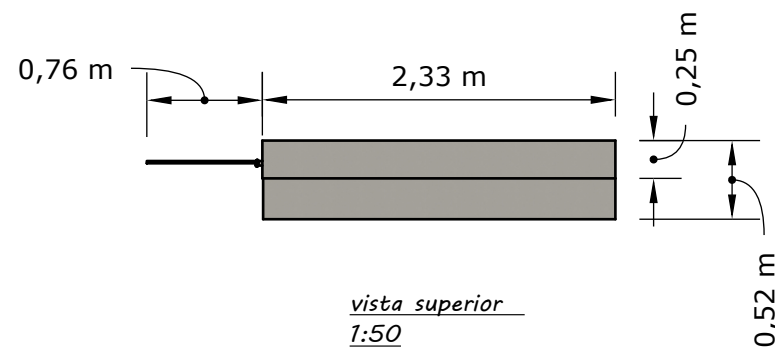

vista superior
1:50

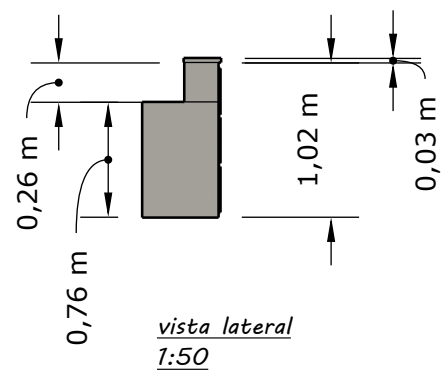

vista lateral
1:50

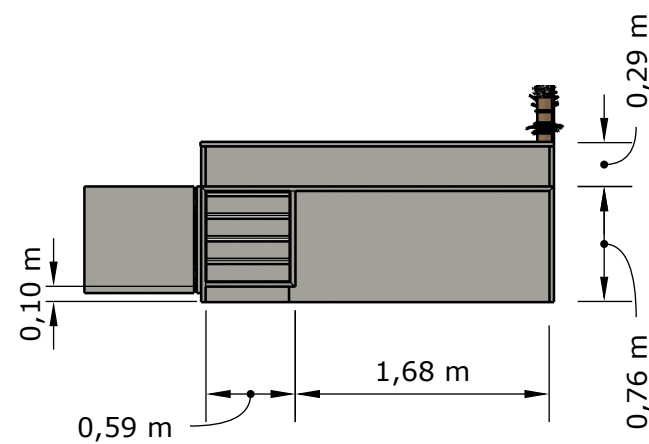

vista frontal (interno)
1:50

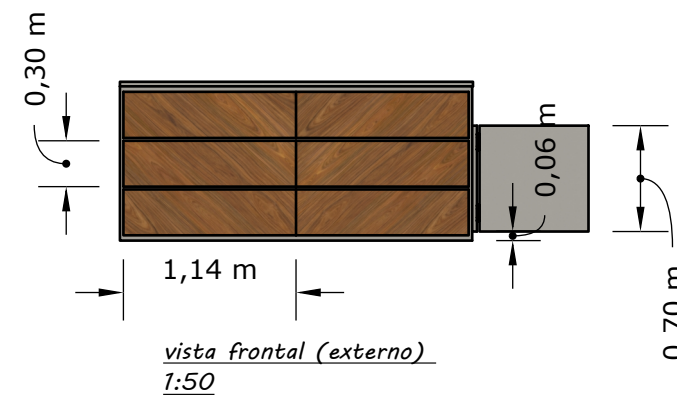

vista frontal (externo)
1:50



Studio link
projetos de interiores
(49) 99828-6943

Cliente: pref capinzal
Local: capinzal

Projeto: secretaria
Data: 03/01/2024

Responsável técnico;
Jackson Schuster

Escala: 1/50

A 03

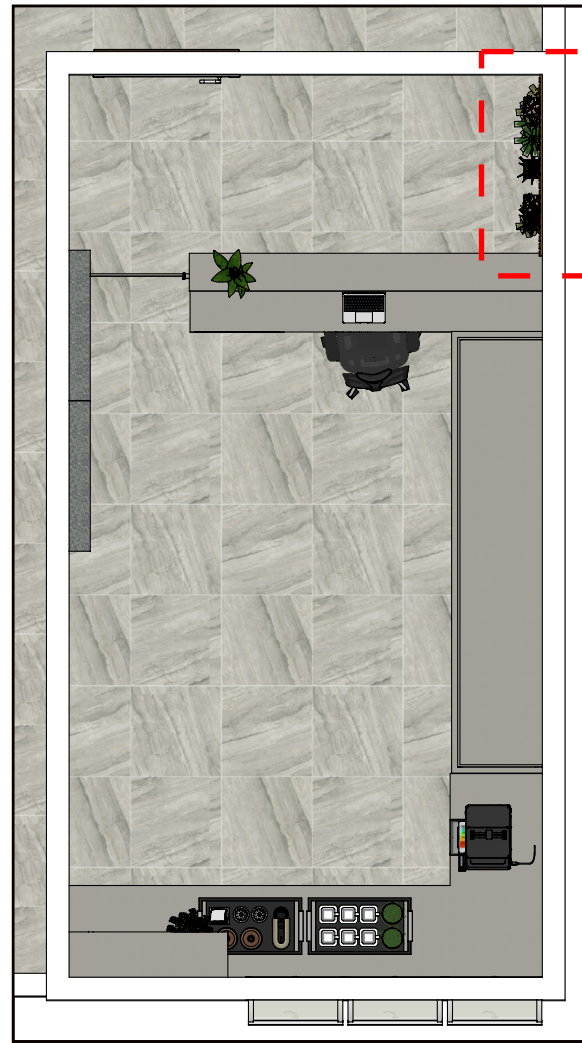

vista planta
1:50

detalhes gerais

- *painel ripado em mdf amadeirado
- *ripas de 05cm com 02cm de folga entre elas
- *estrutura do floreiro em metalon 20x20
- *pintura epóxi cor preta
- *cachepot em madeira maciça laminado da mesma cor do painel

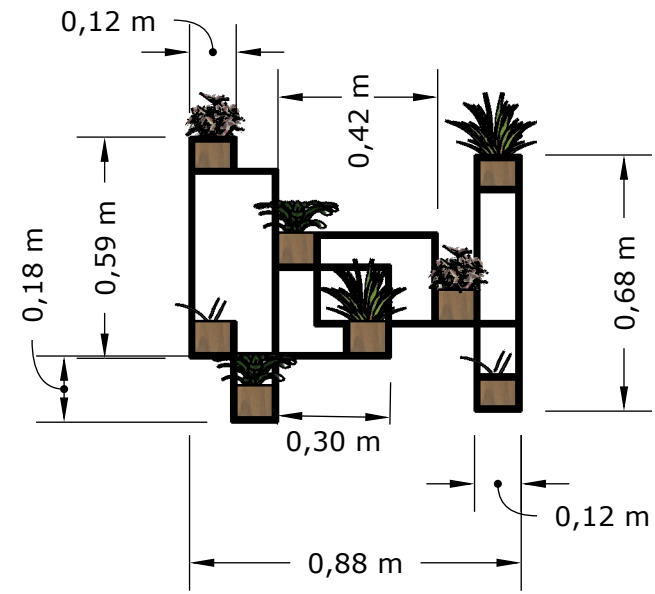

vista frontal
1:20

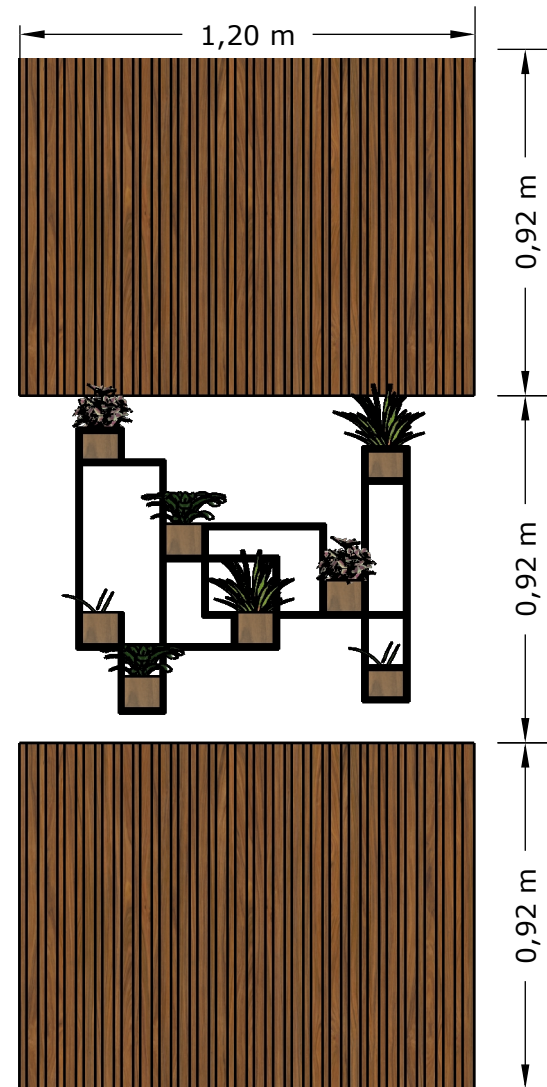

vista frontal
1:20



vista perspectiva
1:50

• painel ripado
ripas de 05cm
com 02 cm de folga



Studio link
projetos de interiores
(49) 99828-6943

Cliente: pref capinzal
Local: capinzal

Projeto: secretaria
Data: 03/01/2024

Responsável técnico;
Jackson Schuster

Escala: 1/20

A 04



vista planta
1:50

detalhes gerais

- *nichos em mdf de 30mm
- *externo cinza interno amadeirado
- *fundo de 15mm para fixação

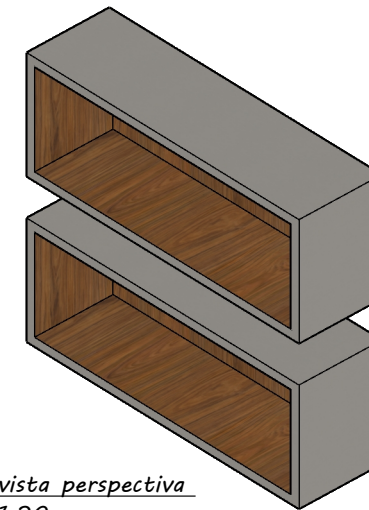

vista perspectiva
1:20

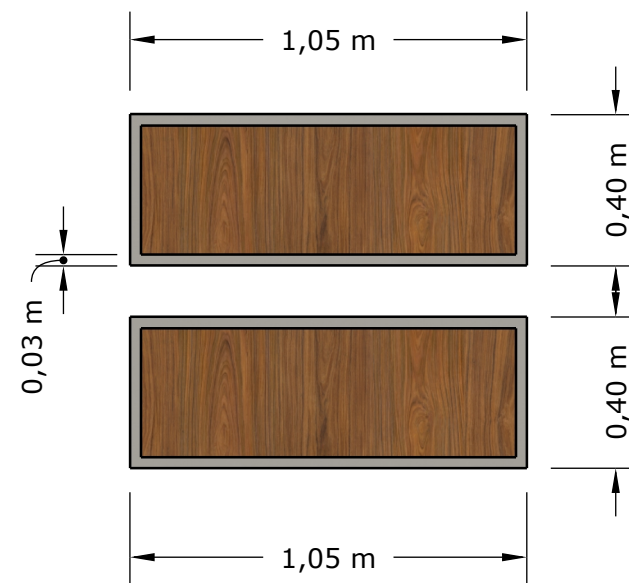

vista frontal
1:20

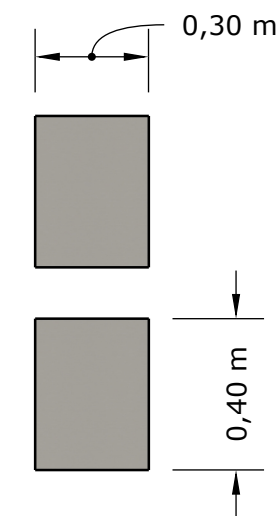

vista lateral
1:20



Studio link
projetos de interiores
(49) 99828-6943

Cliente: pref capinzal
Local: capinzal

Projeto: secretaria
Data: 03/01/2024

Responsável técnico;
Jackson Schuster

Escala: 1/20

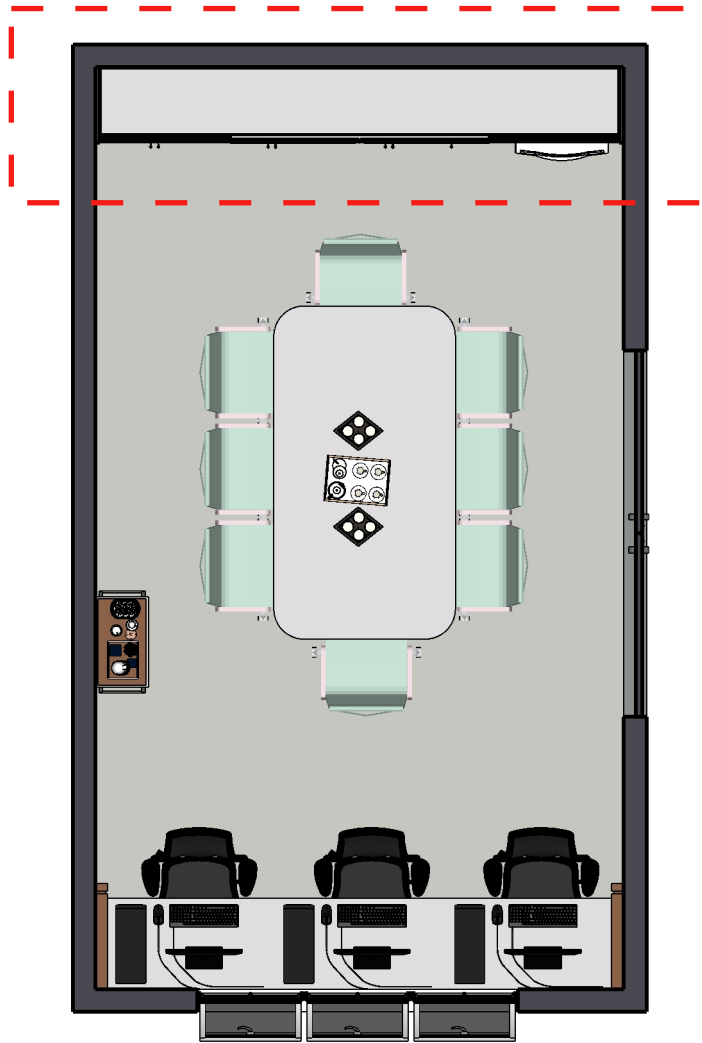

vista planta
1:50

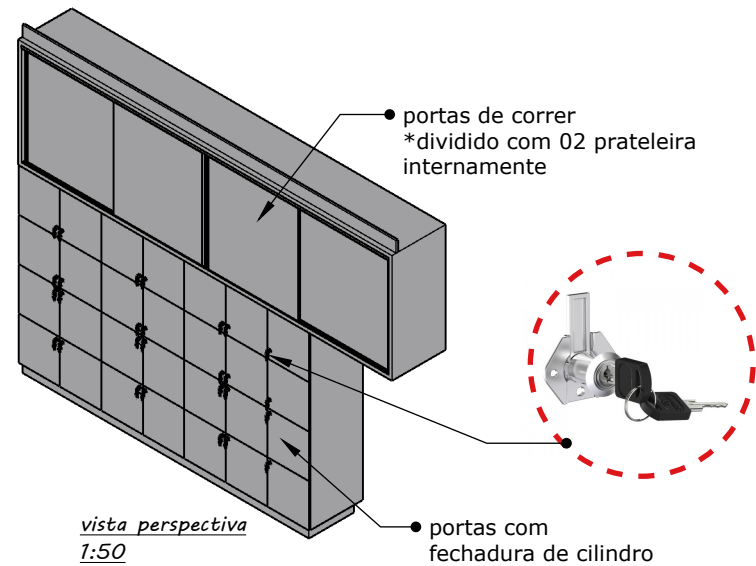

vista perspectiva
1:50

detalhes gerais

- * puxadores de perfil Bilbao com ponteiros de acabamento
- * móvel confeccionado em mdf cinza de 15mm
- * corrediças telescópicas reforçada (larga)
- * dobradiças com sistema de amortecimento (fechamento suave)
- * trilhos superiores e inferiores em alumínio
- * sistema de rodízios de portas roamentado

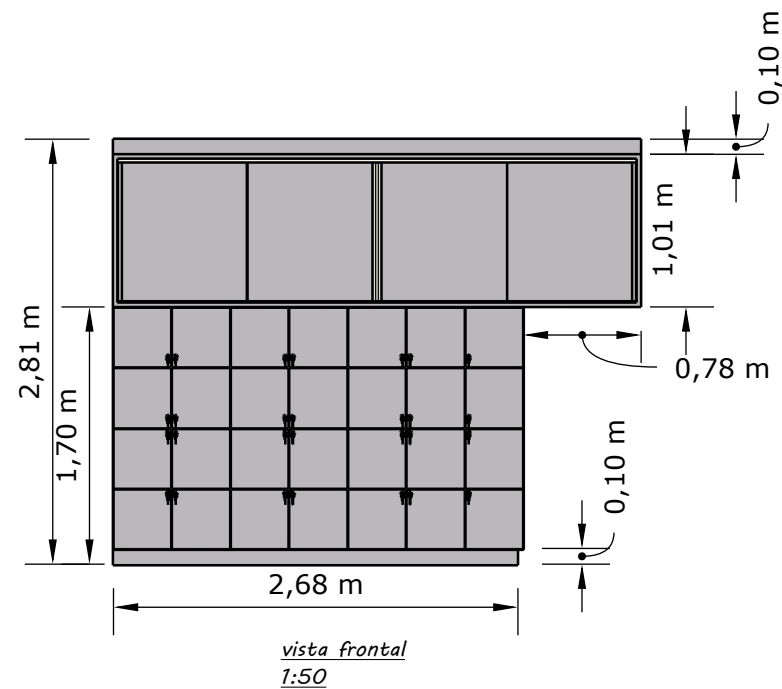

vista frontal
1:50

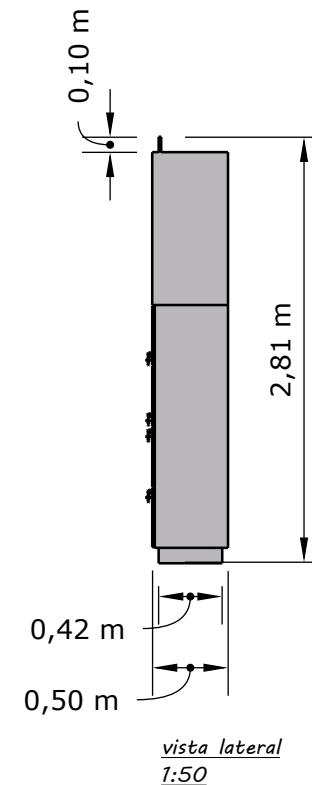

vista lateral
1:50



puxador de perfil em alumínio
com ponteiros de acabamento



Studio link
projetos de interiores
(49) 99828-6943

Cliente: pref capinzal
Local: capinzal

Projeto: sala dos
professores
Data: 03/01/2024

Responsável técnico;
Jackson Schuster

Escala: 1/50

B 01

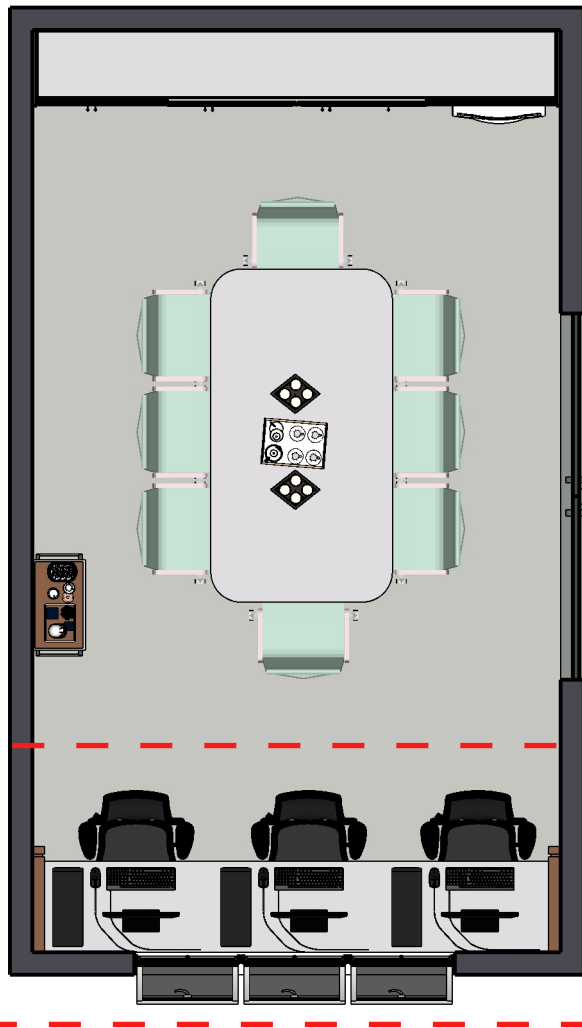

vista planta
1:50

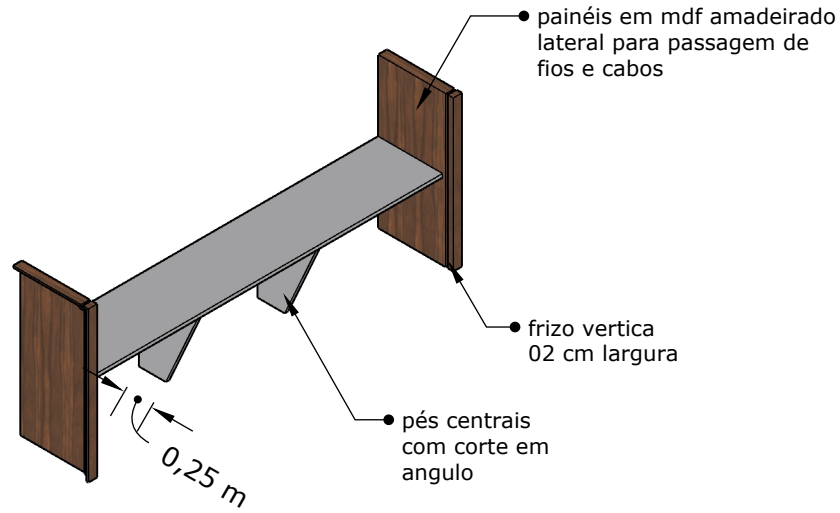

vista perspectiva
1:50

detalhes gerais

- * puxadores de perfil Bilbao com ponteiros de acabamento
- * móvel confeccionado em mdf cinza de 15mm
- * corrediças telescópicas reforçada (larga)
- * dobradiças com sistema de amortecimento (fechamento suave)
- * trilhos superiores e inferiores em alumínio
- * sistema de rodízios de portas roamentado

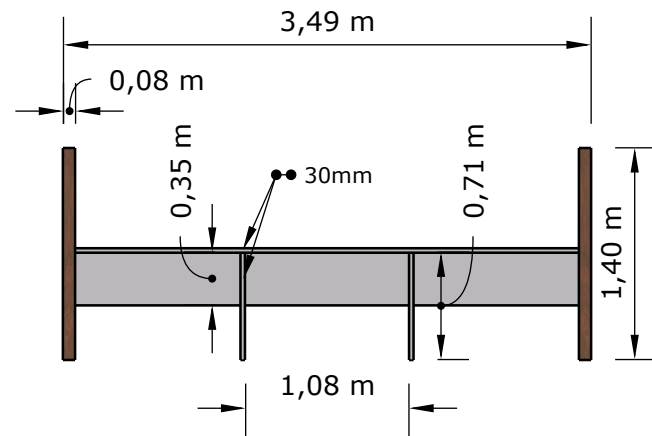

vista frontal
1:50

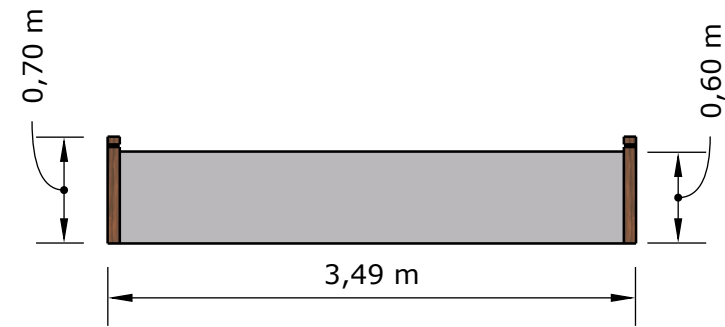

vista topo
1:50

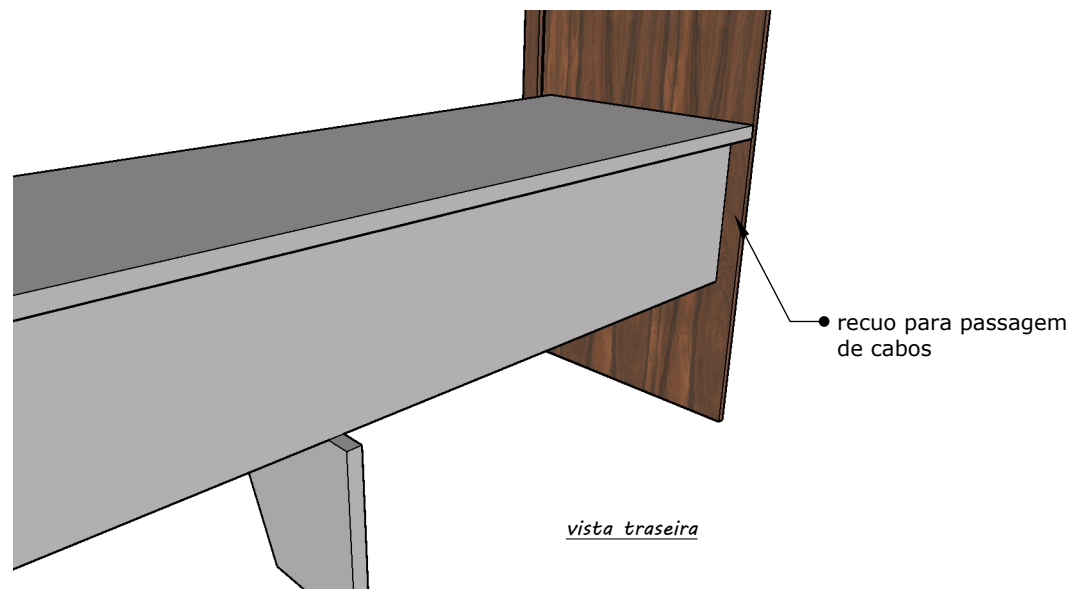

vista traseira

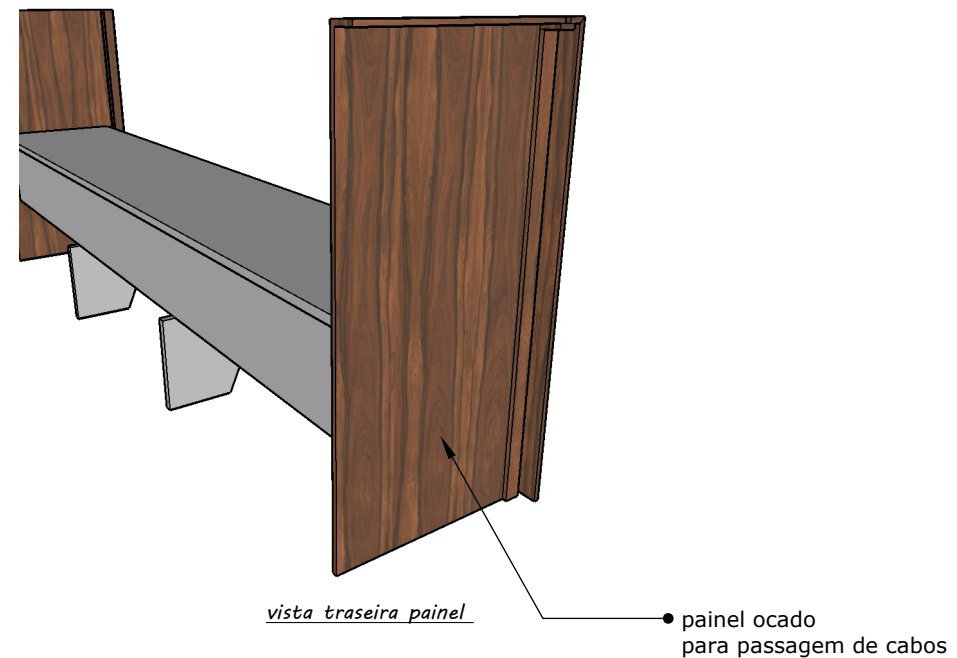

vista traseira painel

painel ocoado para passagem de cabos



Studio link
projetos de interiores
(49) 99828-6943

Cliente: pref capinzal
Local: capinzal

Projeto: sala dos professores
Data: 03/01/2024

Responsável técnico;
Jackson Schuster

Escala: 1/50

B 02

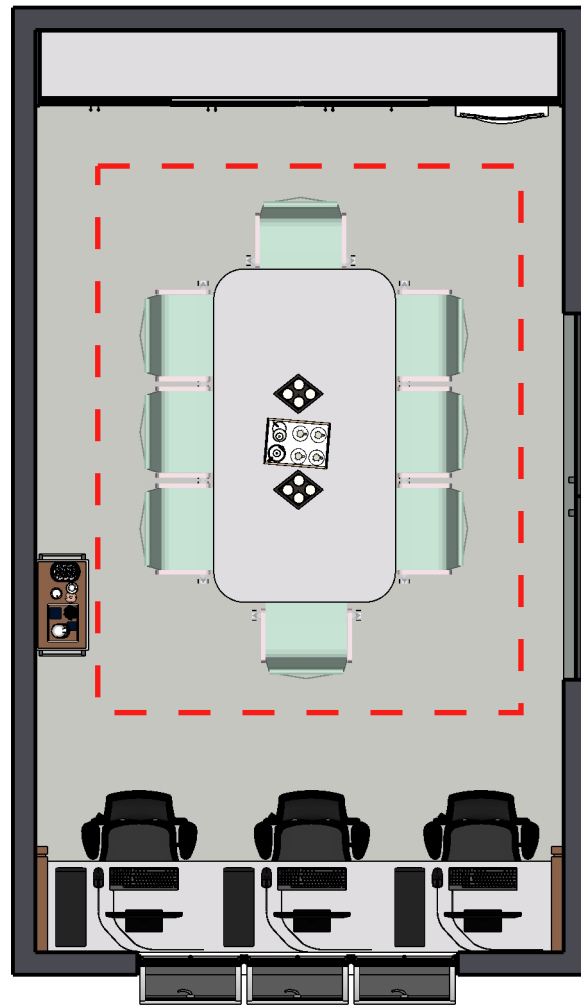

vista planta
1:50

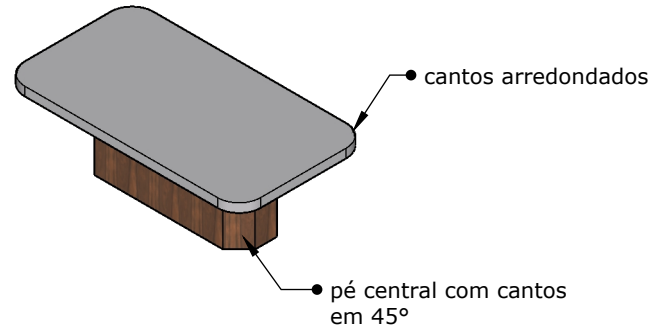

vista perspectiva
1:50

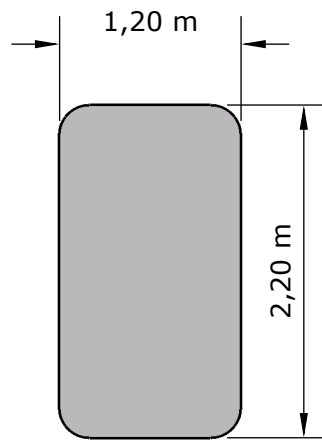

vista topo
1:50

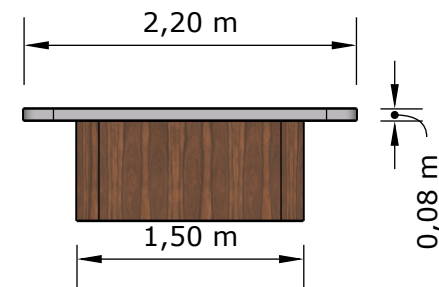

vista lateral
1:50

detalhes gerais

- * mesa retangular com bordas de 80mm
- * cantos arredondados
- * pé central com cantos em 45°
- * tampo em mdf cinza
- * pé central em mdf amadeirado

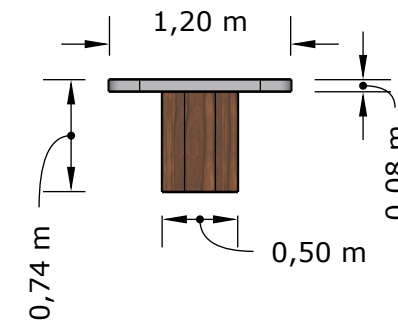

Studio link
projetos de interiores
(49) 99828-6943

Cliente: pref capinzal
Local: capinzal

Projeto: sala dos
professores
Data: 03/01/2024

Responsável técnico;
Jackson Schuster

Escala: 1/50

B 03

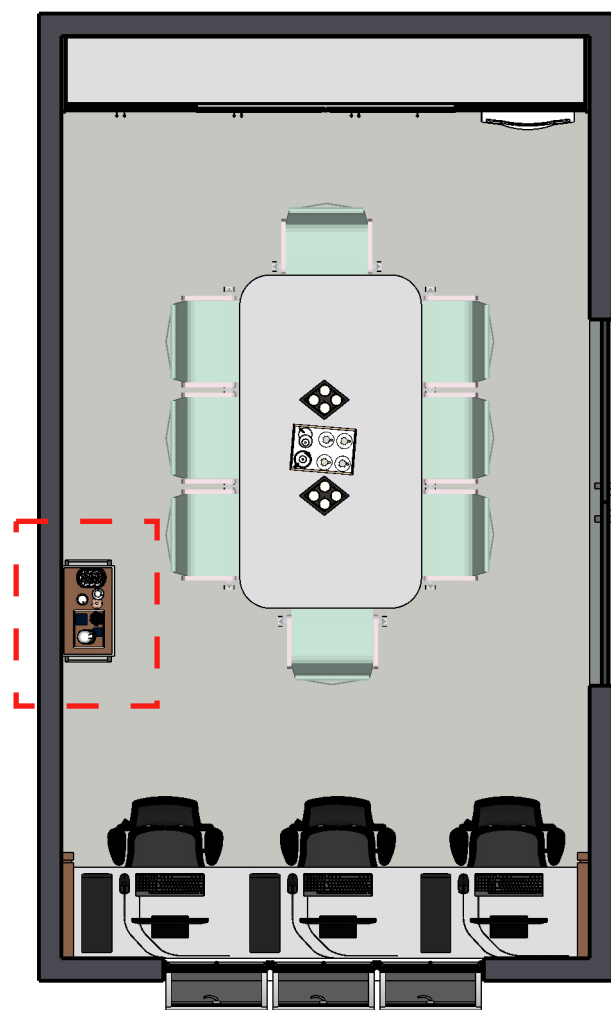

vista planta
1:50

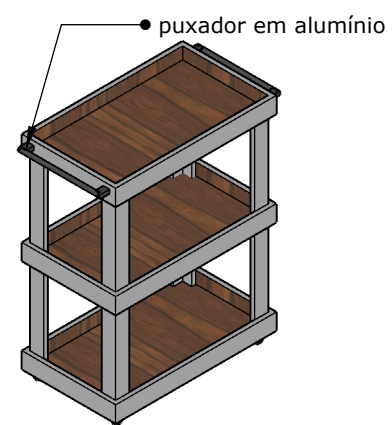

vista perspectiva
1:20

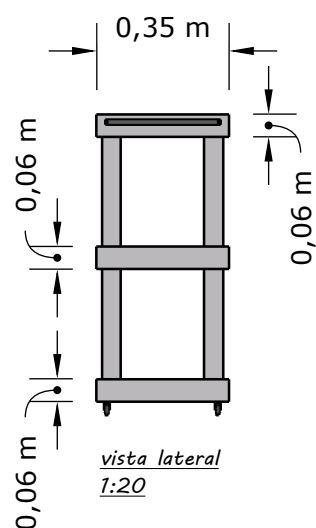

vista lateral
1:20

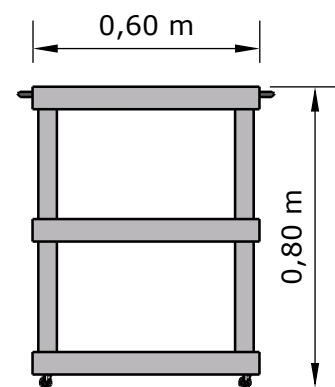

vista frente
1:20

detalhes gerais

- *carrinho para café confeccionado todo em mdf cinza e amadeirado de 15mm
- *rodízios de silicone com travas
- *puxadores nas pontas para móvel o carrinho

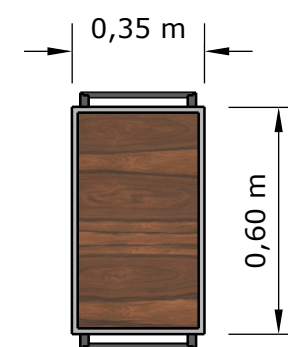

vista superior
1:20



Studio link
projetos de interiores
(49) 99828-6943

Cliente: pref capinzal
Local: capinzal

Projeto: sala dos
professores
Data: 03/01/2024

Responsável técnico;
Jackson Schuster

Escala: 1/20

ARMARIO 01

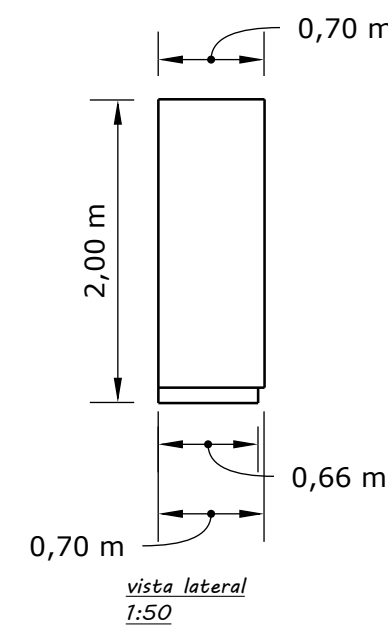
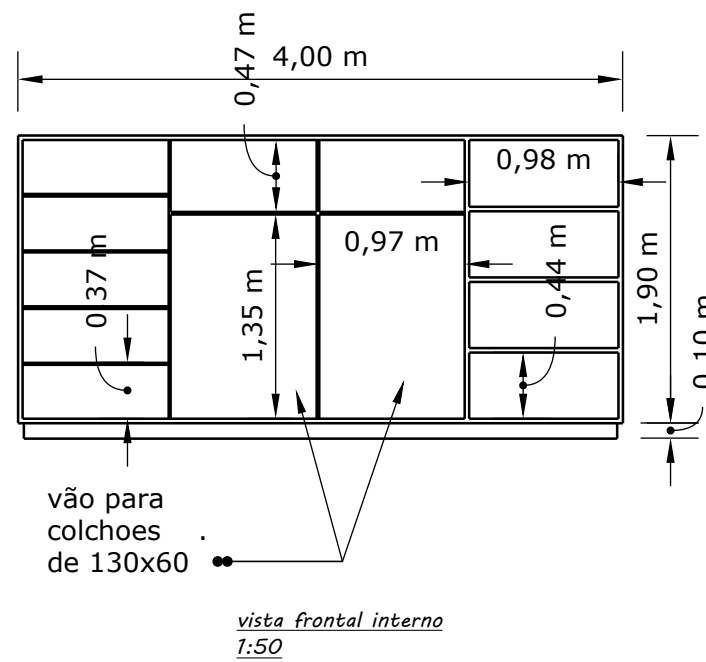
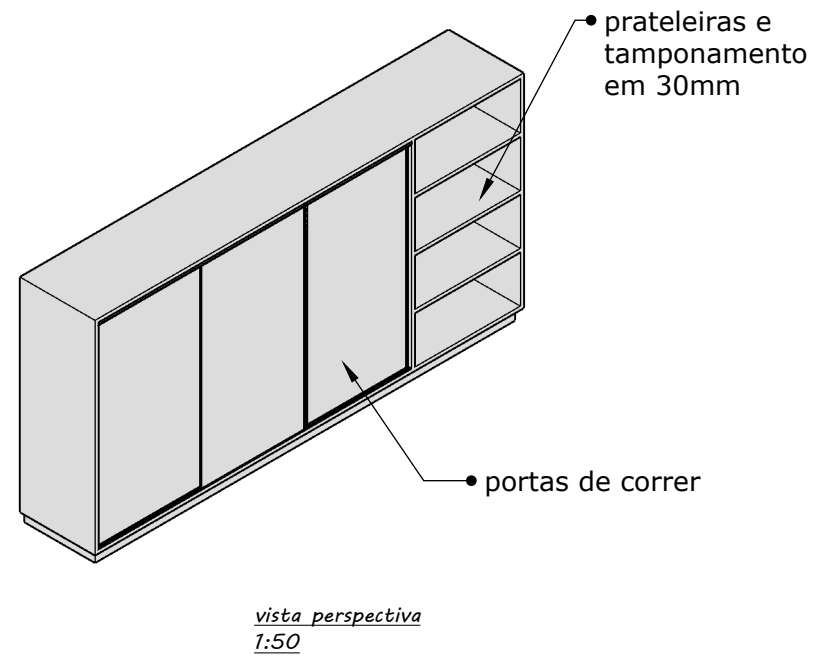
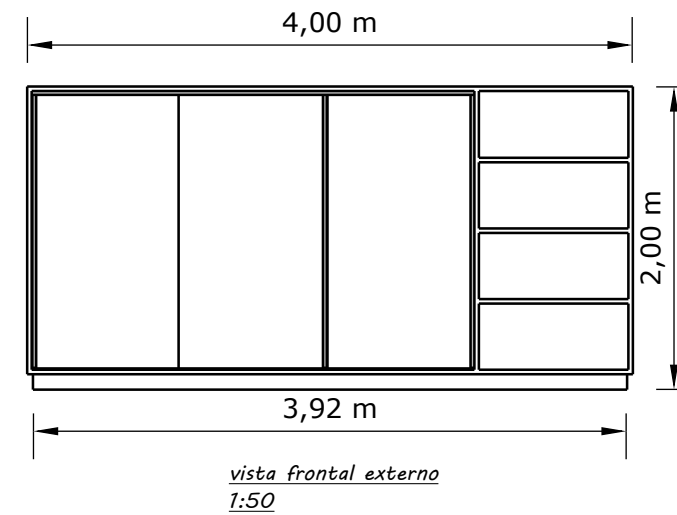

Studio link
projetos de interiores
(49) 99828-6943

Cliente: pref capinzal
Local: capinzal

Projeto: armarios
salas
Data: 03/01/2024

Responsável técnico;
Jackson Schuster

Escala: 1/50

C 01

ARMARIO 02

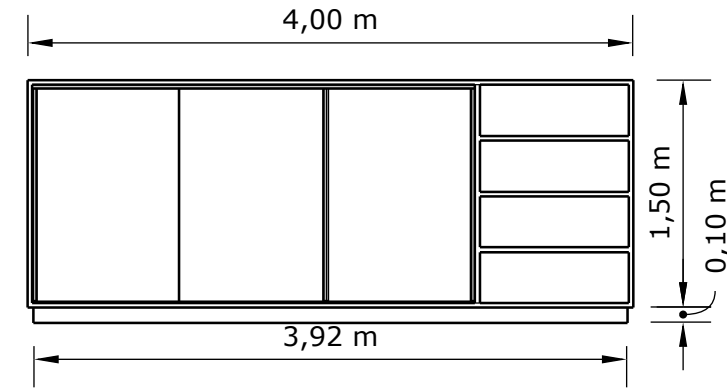

vista frontal externo
1:50

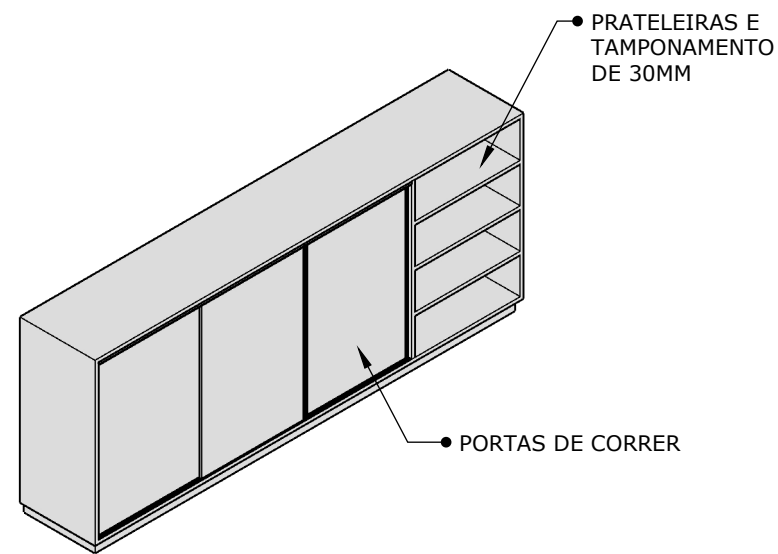

vista perspectiva
1:50

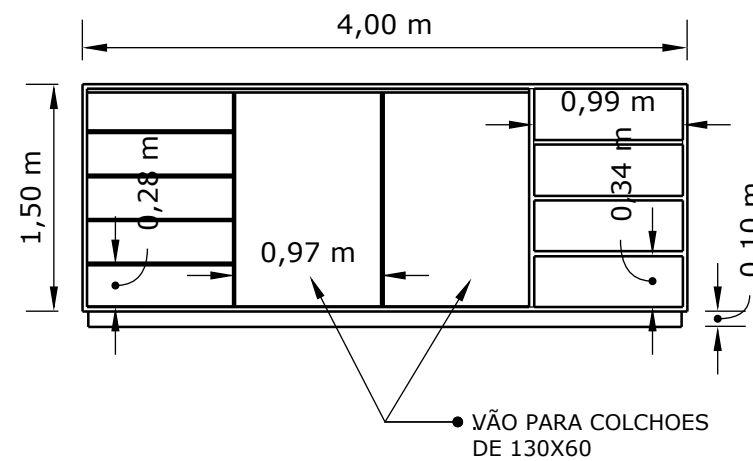

vista frontal interno
1:50

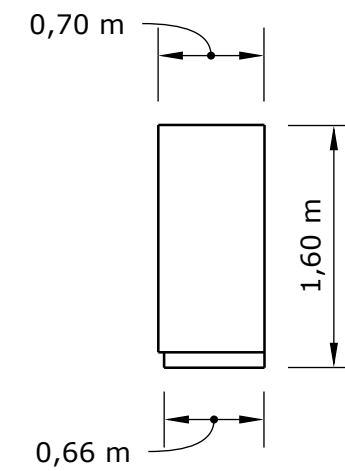

vista lateral
1:50



Studio link
projetos de interiores
(49) 99828-6943

Cliente: pref capinzal
Local: capinzal

Projeto: armarios
salas
Data: 03/01/2024

Responsável técnico;
Jackson Schuster

Escala: 1/50

C 02



ARMARIO 01



ARMARIO 02

INFORMAÇÕES GERAIS

*armário 01 serão confeccionados 06 unidades
*todo em mdf branco 15mm
*trilhos superior e inferior das portas em alumínio
*rodízios das portas com rolamento
*puxador de perfil em alumínio Bilbao

*armário 02 serão confeccionados 04 unidades
*todo em mdf branco 15mm
*trilho superior e inferior das portas em alumínio
*rodízios das portas com rolamento
*puxador de perfil em alumínio Bilbao

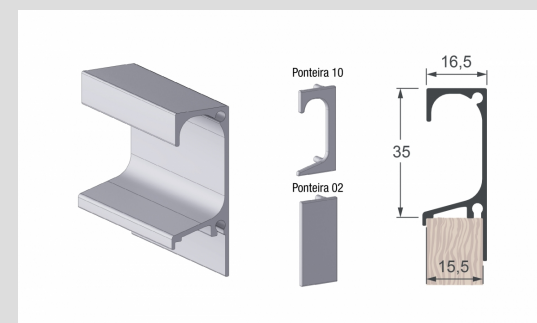

Studio link
projetos de interiores
(49) 99828-6943

Cliente: pref capinzal
Local: capinzal

Projeto: armarios
salas
Data: 03/01/2024

Responsável técnico;
Jackson Schuster

Escala: 1/50

C 03



studio link
projetos de interiores
(49) 99828-6943

Cliente: pref capinzal
Local: capinzal

Projeto: sala dos
professores
Data: 25/11/2023

Responsável técnico;
Jackson Schuster



D 01



Studio link
projetos de interiores
(49) 99828-6943

Cliente: pref capinzal
Local: capinzal

Projeto: sala dos
professores
Data: 03/01/2024

Responsável técnico;
Jackson Schuster

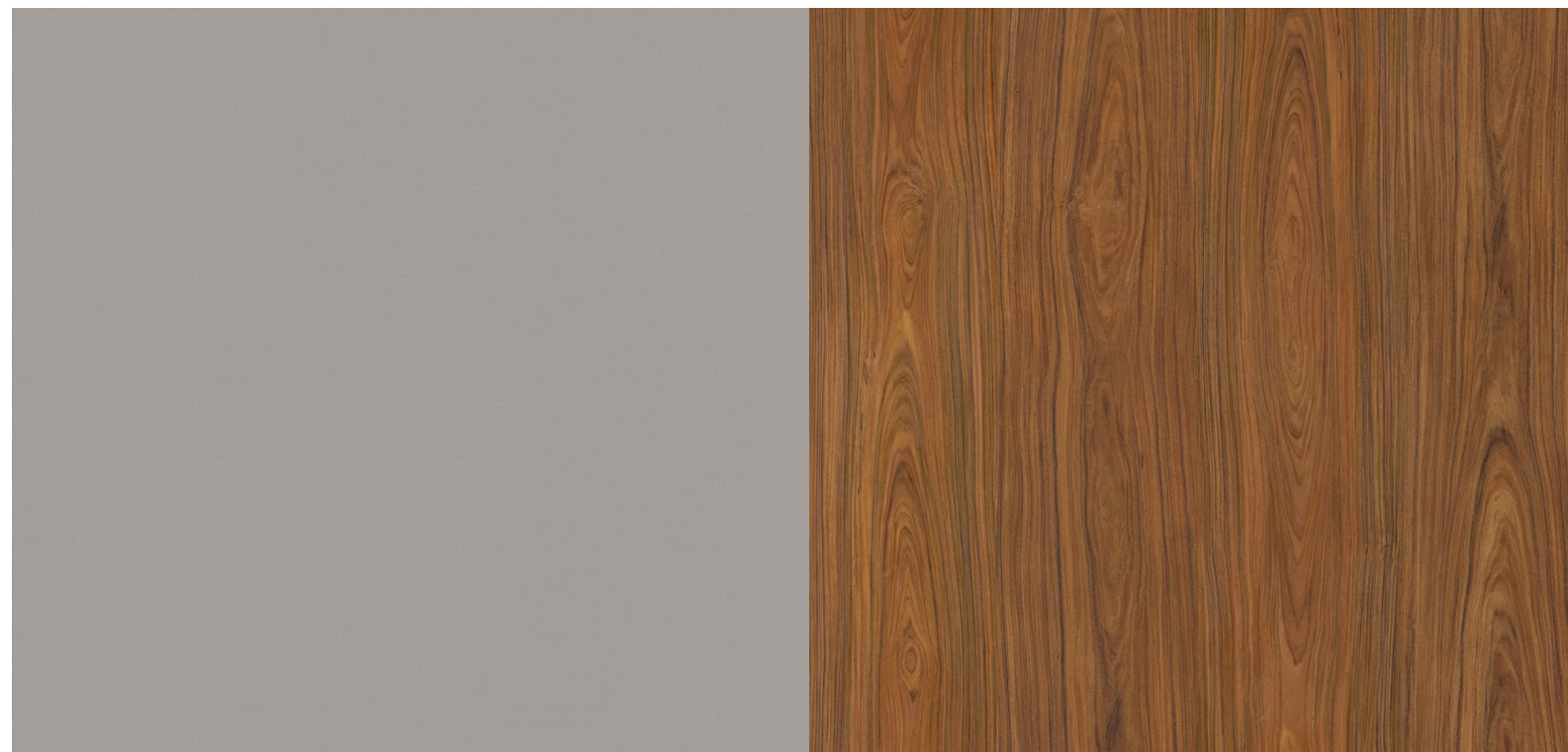

SUGESTOES DE CORES



Studio link
projetos de interiores
(49) 99828-6943

Cliente: pref capinzal
Local: capinzal

Projeto: secretaria
Data: 03/01/2024

Responsável técnico;
Jackson Schuster

D 03

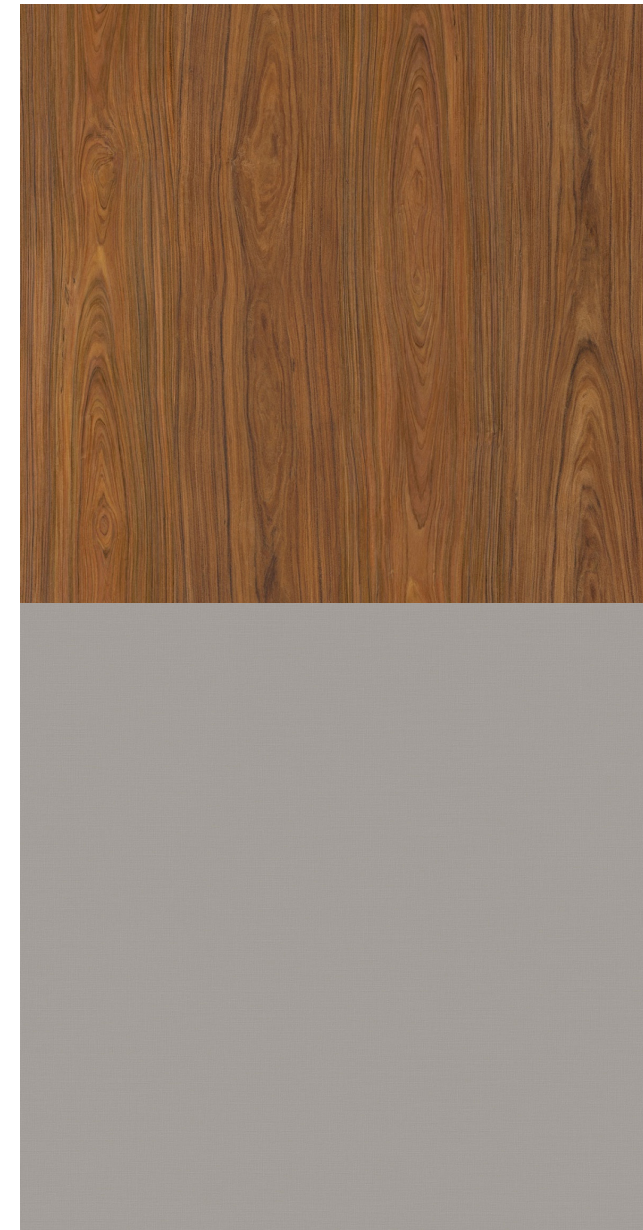

sugestão de cores



Studio link
projetos de interiores
(49) 99828-6943

Cliente: pref capinzal
Local: capinzal

Projeto: secretaria
Data: 03/01/2024

Responsável técnico;
Jackson Schuster
