

PLACAS DE ADVERTÊNCIA

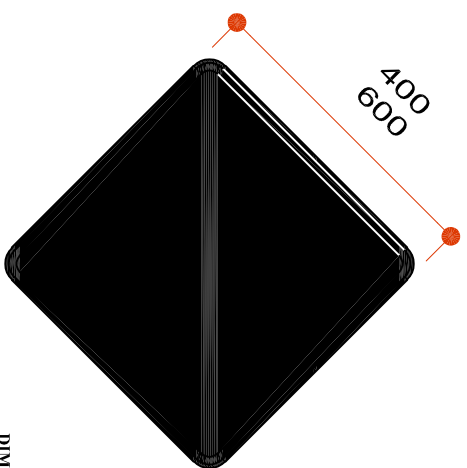

DIMENSÕES:
LADO: 600
ORLA INTERNA: 30
ORLA EXTERNA: 20

SUPORTE

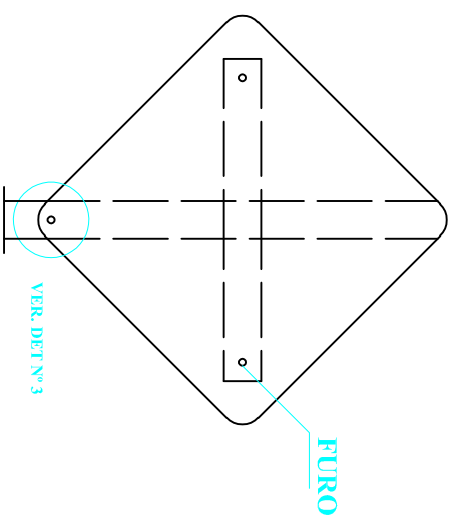

PLACAS DE REGULAMENTAÇÃO

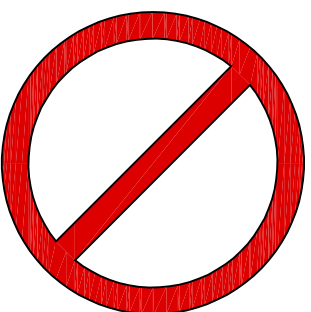

DIMENSÕES:
DIÂMETRO: 500
TABUA:
ORLA: 90

SUPORTE

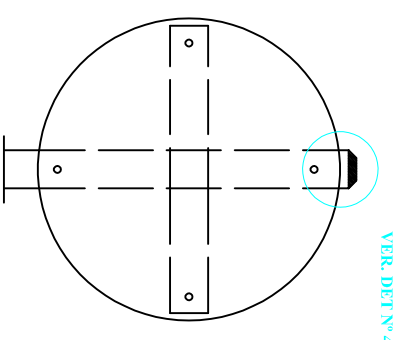

DETALHE N° 2

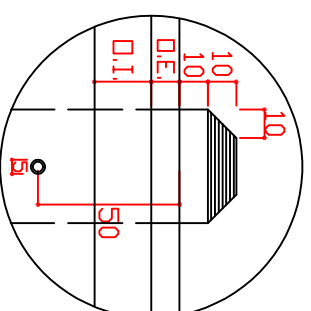

DETALHE N° 4

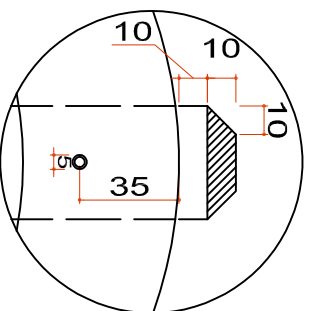

DETALHE N° 3

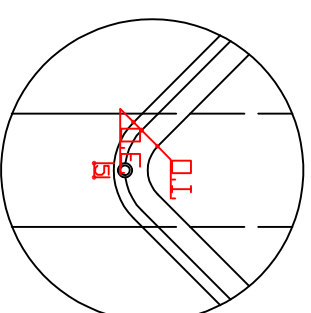

TACHINHAS

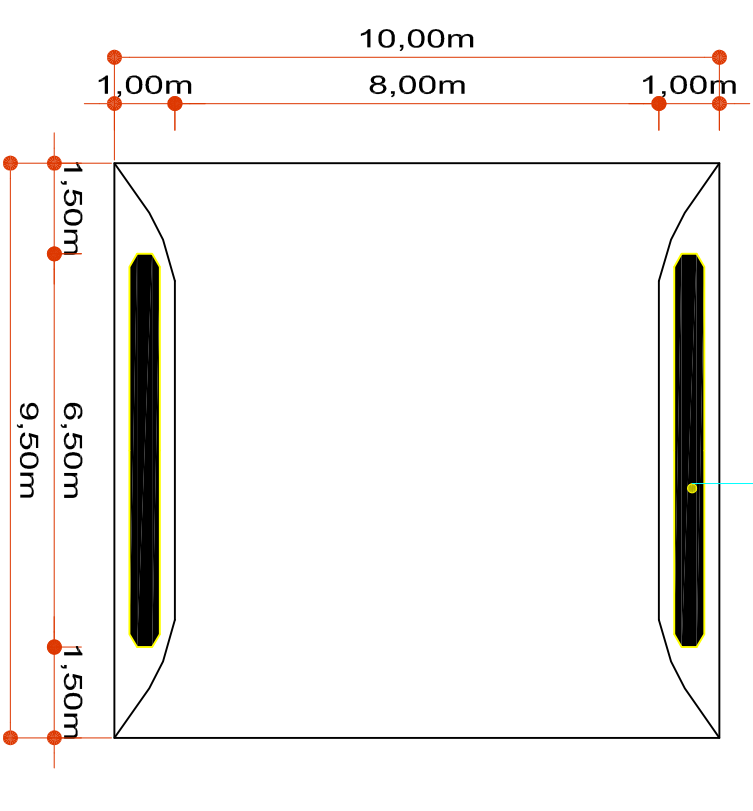

PLANTA

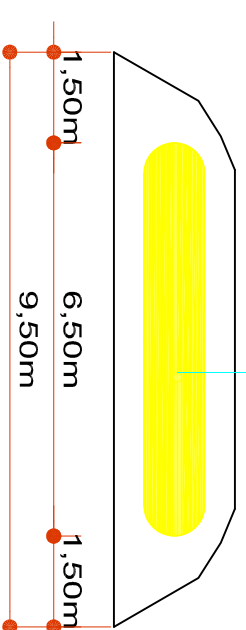

VISTA FRONTAL

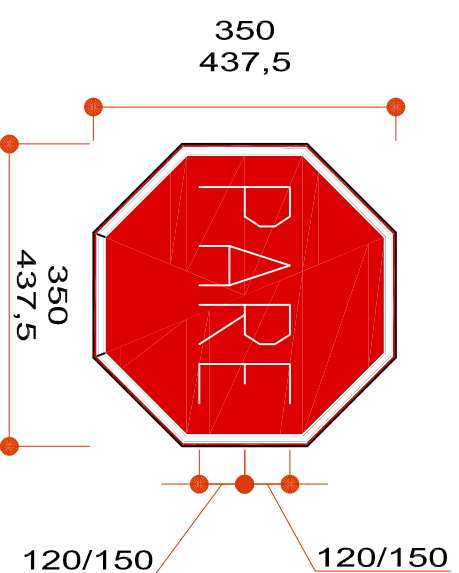

DIMENSÕES:
LADO: 350
ORLA INTERNA: 20
ORLA EXTERNA: 10

RESPONSÁVEL TÉCNICO

PREFEITO MUNICIPAL

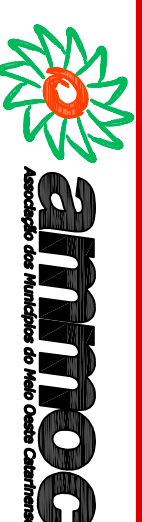

Quadro Técnico:

ANA JULIA UNGERICH - ENG. CIVIL-CREA/SC 105.295-8
ANDRÉ BRITO DOTTI - ENG. CIVIL-CREA/SC 182.237-5
DENIR NARCIZO ZULIAN - ENG. CIVIL - CREA/SC 30.805-8
LUCAS FELIPE BALESTRIN - ENG. AGRÔNOMO-CREA/SC 156.743-7
MAX MOOSHAMMER - ENG. CIVIL - CREA/SC 139.164-0

Desenho: MICHEL / LUCAS

AGOSTO DE 2017

Revisão: FEVEREIRO DE 2020

Escala: (INDICADA(S))

06/07

Projeto: PLANTA DE SINALIZAÇÃO

Trecho: Est. OPP - 312+0,00